

- Tentative Specification
- Preliminary Specification
- Approval Specification

**MODEL NO.: G101ICE**  
**SUFFIX: L01**

<b>Customer: Rational</b>	
<b>APPROVED BY</b>	<b>SIGNATURE</b>
<u>Name / Title</u>	_____
Note	
<p>_____</p> <p>Please return 1 copy for your confirmation with your signature and comments.</p>	

Approved By	Checked By	Prepared By
yuhsiang.chang (張喻翔/514-10922)	yuhsiang.chang (張喻翔/514-10922)	ying.xin (忻瑩/562-19748)
2016-05-03 15:05:17 CST	2016-05-03 15:05:17 CST	2016-05-03 12:01:09 CST

**REVISION HISTORY**

Version	Date	Section	Description
Ver. 3.0	21 Apr., 2016	All	Approval Specification was first issued.

## 1. GENERAL DESCRIPTION

### 1.1 OVERVIEW

G101ICE-L01 is a 10.1" TFT Liquid Crystal Display module with LED Backlight units and 40 pins LVDS interface. This module supports 1280 x 800 WXGA mode and can display 16.2M/ 262k colors. The LED driving device for Backlight is built in PCBA.

### 1.2 FEATURES

- WXGA (1280 x 800 pixels) resolution
- DE (Data Enable) only mode
- LVDS Interface with 1pixel/clock
- Wide operating temperature.
- RoHS compliance

### 1.3 APPLICATION

- TFT LCD Monitor
- Factory Application
- Amusement

### 1.4 GENERAL SPECIFICATIONS

Item	Specification	Unit	Note
Active Area	216.96 (H) x 135.60 (V) (10.1" diagonal)	mm	(1)
Bezel Opening Area	218.96 (H) x 137.6 (V)	mm	
Driver Element	a-Si TFT active matrix	-	-
Pixel Number	1280 x R.G.B x 800	pixel	-
Pixel Pitch	0.1695 (H) x 0.1695 (V)	mm	-
Pixel Arrangement	RGB vertical Stripe	-	-
Display Colors	16,194,277 / 262,144	color	-
Display Mode	Normally Black	-	-
Surface Treatment	Hard Coating (3H), Anti-Glare	-	-
Module Power Consumption	9	W	Typical

**1.5 MECHANICAL SPECIFICATIONS**

Item		Min.	Typ.	Max.	Unit	Note
Module Size	Horizontal(H)	230.2	230.7	231.2	mm	(1)
	Vertical(V)	152.05	152.55	153.05	mm	
	Depth(D)	6.0	6.5	7.0	mm	(1)(2)
Bezel Area	Horizontal	217.66	218.96	219.26	mm	
	Vertical	137.3	137.6	137.9	mm	
Active Area	Horizontal	-	216.96	-	mm	
	Vertical	-	135.6	-	mm	
Weight		-	360	375	g	

Note (1) Please refer to the attached drawings for more information of front and back outline dimensions.

Note (2) The depth is without connector.

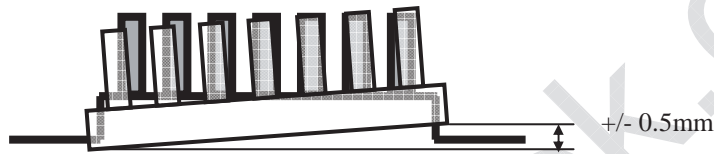

**2. ABSOLUTE MAXIMUM RATINGS**

**2.1 ABSOLUTE RATINGS OF ENVIRONMENT**

Item	Symbol	Value		Unit	Note
		Min.	Max.		
Operating Ambient Temperature	T <sub>OP</sub>	-20	+70	°C	
Storage Temperature	T <sub>ST</sub>	-25	+70	°C	

Note (1) Temperature and relative humidity range is shown in the figure below.

- (2) 90 %RH Max. (Ta < 40°C).
- (3) Wet-bulb temperature should be 39°C Max.
- (4) No condensation.
- (5) For module only

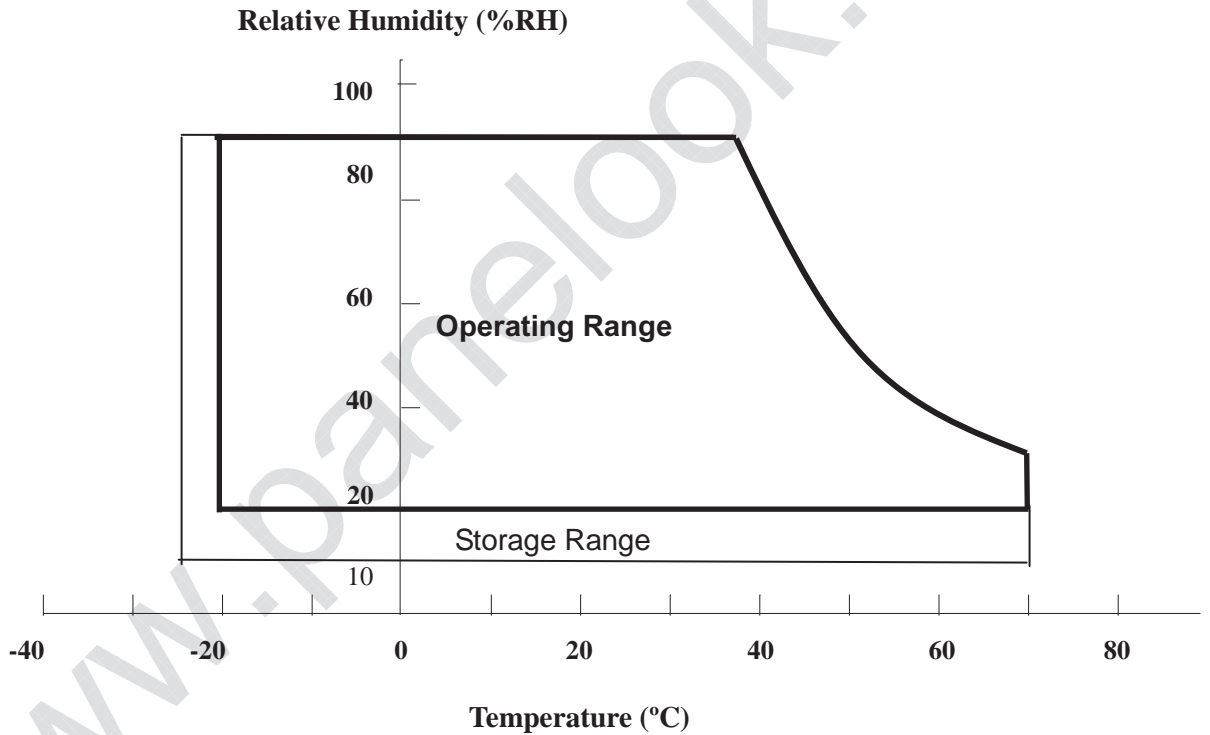

## 2.2 ELECTRICAL ABSOLUTE RATINGS

### 2.2.1 TFT LCD MODULE

Item	Symbol	Value		Unit	Note
		Min.	Max.		
Power Supply Voltage	VCC	-0.3	4	V	(1)

### 2.2.2 BACKLIGHT UNIT

Item	Symbol	Value		Unit	Note
		Min.	Max.		
Converter Voltage	$V_i$	-0.3	18	V	(1), (2)
Enable Voltage	EN	---	5.5	V	
Backlight Adjust	ADJ	---	5.5	V	

Note (1) Permanent damage to the device may occur if maximum values are exceeded. Function operation should be restricted to the conditions described under Normal Operating Conditions.

Note (2) Specified values are for lamp (Refer to 3.2 for further information).

### 3. ELECTRICAL CHARACTERISTICS

#### 3.1 TFT LCD MODULE

Parameter	Symbol	Value			Unit	Note
		Min.	Typ.	Max.		
Power Supply Voltage	$V_{CC}$	3.0	3.3	3.6	V	-
Ripple Voltage	$V_{RP}$	-	-	100	mVp-p	
Rush Current	$I_{RUSH}$	-	-	1.5	A	(2)
Power Supply Current	White	-	265	320	mA	(3)a
	Black	-	210	260	mA	(3)b
LVDS differential input voltage	$V_{id}$	200	-	600	mV	
LVDS common input voltage	$V_{ic}$	1.0	1.2	1.4	V	
Differential Input Voltage for LVDS Receiver Threshold	"H" Level			100	mV	-
	"L" Level	-100			mV	-
Terminating Resistor	$R_T$	-	100		Ohm	-

Note (1) The module should be always operated within above ranges.

Note (2) Measurement Conditions:

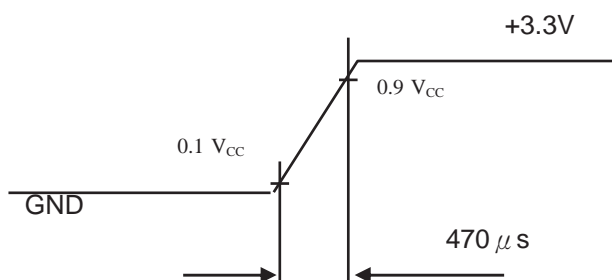
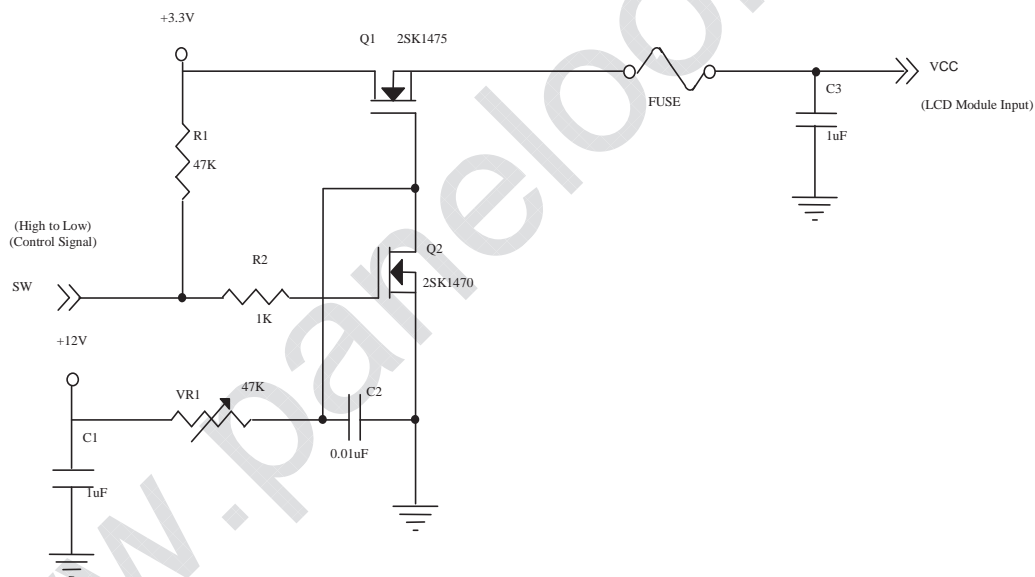

Note (3) The specified power supply current is under the conditions at  $V_{DD} = 3.3V$ ,  $T_a = 25 \pm 2 \text{ }^\circ\text{C}$ , DC Current and  $f_v = 60 \text{ Hz}$ , whereas a power dissipation check pattern below is displayed.

a. White Pattern



Active Area

b. Black Pattern



Active Area

### 3.2 BACKLIGHT UNIT

 $T_a = 25 \pm 2 \text{ }^\circ\text{C}$ 

Parameter	Symbol	Value			Unit	Note	
		Min.	Typ.	Max.			
Converter Power Supply Voltage	$V_i$	10.8	12.0	13.2	V		
Converter Power Supply Current	$I_i$	-	0.45	0.50	A	@ $V_i = 12V$ (Duty 100%)	
Backlight Power Consumption	$P_{BL}$	-	5.3	5.8	W	@ $V_i = 12V$ (Duty 100%)	
EN Control Level	Backlight on	-	2.5	3.3	5.0	V	
	Backlight off	-	0	---	0.8	V	
PWM Control Level	PWM High Level	-	2.5	3.3	5.0	V	
	PWM Low Level	-	0	-	0.15	V	
PWM Control Duty Ratio	-	1	-	100	%	@200Hz	
PWM Control Frequency	$f_{PWM}$	190	200	20k	Hz	(2)	
LED Life Time	$L_L$	50,000	-	-	Hrs	(3)	

Note (1) LED current is measured by utilizing a high frequency current meter as shown below:

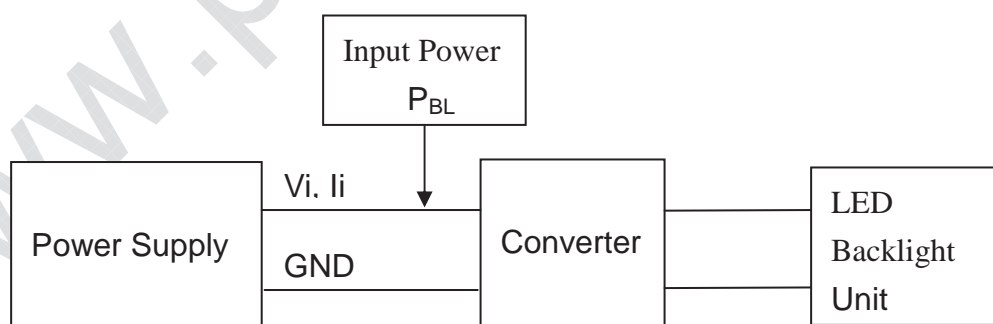

Note (2) At 200 Hz PWM control frequency, duty ratio range is restricted from 1% to 100%

Note (3) The lifetime of LED is defined as the time when it continues to operate under the conditions at  $T_a = 25 \pm 2 \text{ }^\circ\text{C}$  and Duty 100% until the brightness becomes  $\leq 50\%$  of its original value. Operating LED under high temperature environment will reduce life time and lead to color shift.



Power sequence and control signal timing are shown in the following figure

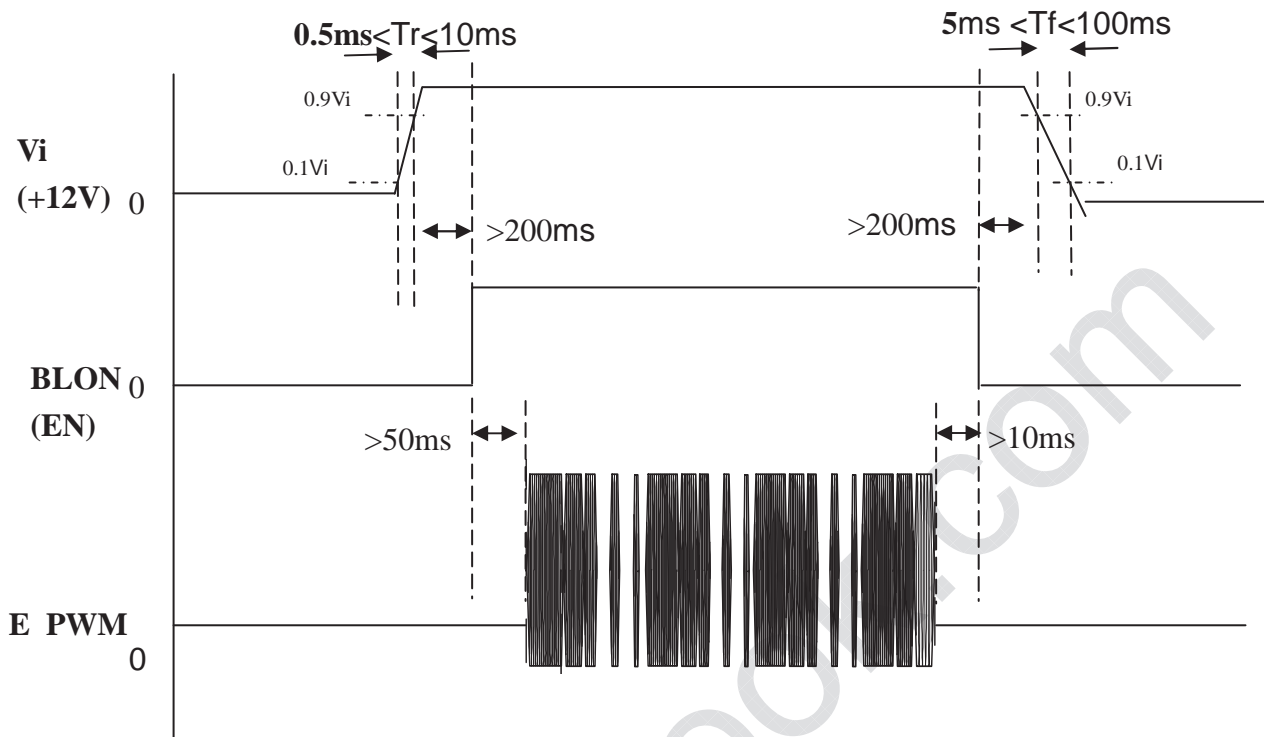

Note : While system is turned ON or OFF, the power sequences must follow as below descriptions

Turn ON sequence: Vi(+12V) → BLON → E\_PWM signal

Turn OFF sequence: E\_PWM signal → BLON → Vi(+12V)

## 4. BLOCK DIAGRAM

### 4.1 TFT LCD MODULE

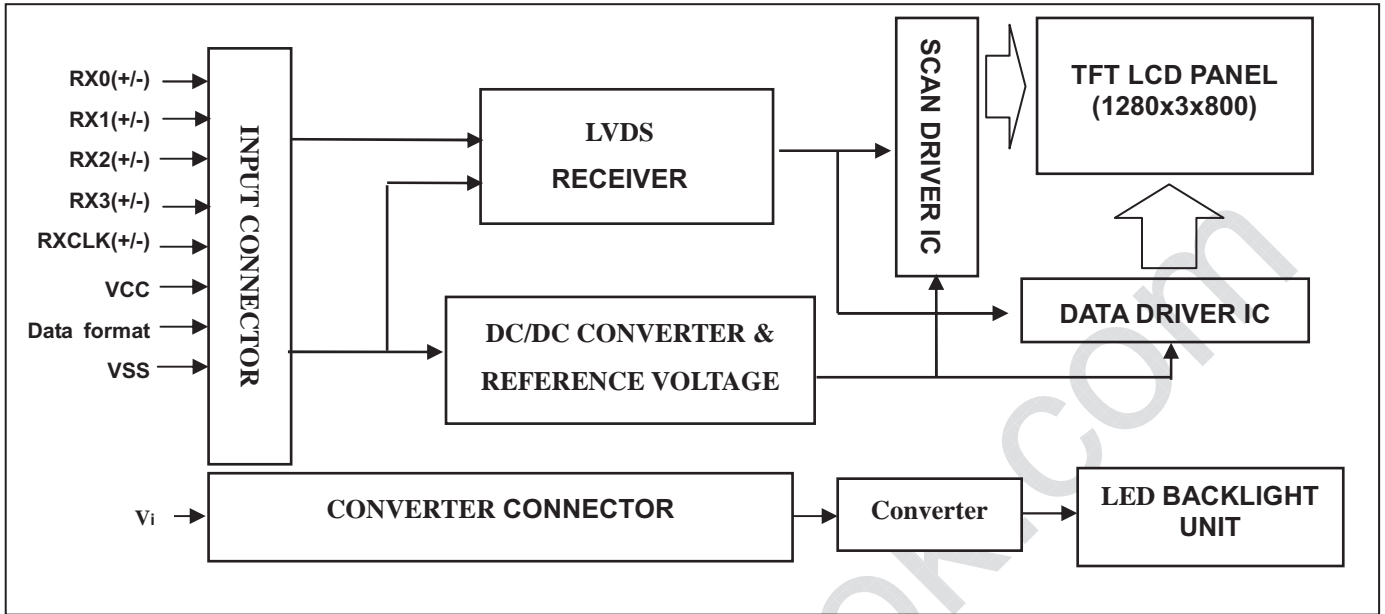

## 5. INPUT TERMINAL PIN ASSIGNMENT

### 5.1 TFT LCD MODULE

Pin No.	Symbol	Function	Polarity	Note
1	VCCS	Power Supply +3.3V(typical)		
2	VCCS	Power Supply +3.3V(typical)		
3	VCCS	Power Supply +3.3V(typical)		
4	Data format	L or NC : 8bit Input Mode H : 6bit Input Mode		Note (2),Note(3)
5	NC	No Connction (Reserve for INX test)		
6	NC	No Connction (Reserve for INX test)		
7	NC	No Connction (Reserve for INX test)		
8	Rxin0-	LVDS Differential Data Input	Negative	
9	Rxin0+	LVDS Differential Data Input	Positive	
10	VSS	Ground		
11	Rxin1-	LVDS Differential Data Input	Negative	
12	Rxin1+	LVDS Differential Data Input	Positive	
13	VSS	Ground		
14	Rxin2-	LVDS Differential Data Input	Negative	
15	Rxin2+	LVDS Differential Data Input	Positive	
16	VSS	Ground		
17	RxCLK-	LVDS Differential Clock Input	Negative	
18	RxCLK+	LVDS Differential Clock Input	Positive	
19	VSS	Ground		
20	Rxin3-	LVDS Differential Data Input	Negative	
21	Rxin3+	LVDS Differential Data Input	Positive	
22	VSS	Ground		
23	NC	No Connction (Reserve)		
24	NC	No Connction (Reserve)		
25	VSS	Ground		
26	VSS	Ground		
27	LED_PWM	PWM Control Signal od LED Converter		
28	LED_EN	Enable Control Signal od LED Converter		
29	LED_GND	LED Ground		
30	LED_GND	LED Ground		
31	LED_GND	LED Ground		
32	LED_GND	LED Ground		
33	LED_GND	LED Ground		
34	NC	No Connction (Reserve)		
35	NC	No Connction (Reserve)		
36	LED_VCCS	LED Power Supply		
37	LED_VCCS	LED Power Supply		
38	LED_VCCS	LED Power Supply		
39	LED_VCCS	LED Power Supply		
40	LED_VCCS	LED Power Supply		

Note (1) Connector Part No.: I-PEX 20455-040E-12 or Tyco\_5-2069716-3.

Note (2) "Low" stands for 0V. "High" stands for 3.3V. "NC" stands for "No Connection".

Note (3) Interface optional pin has internal scheme as following diagram, Customer should keep the interface voltage level requirement which including panel board loading as below.

**Data format Pin**

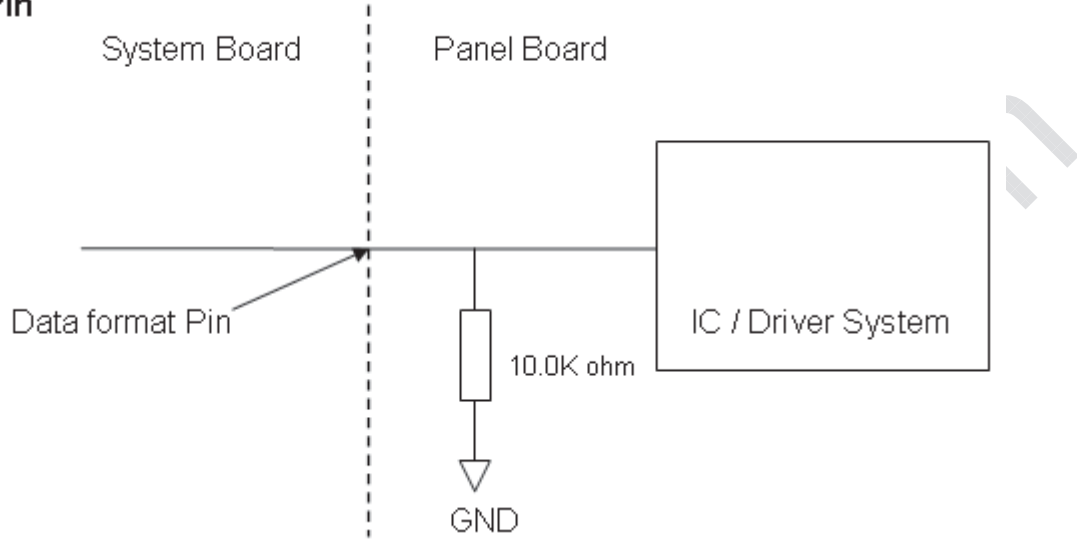



PRODUK

5.2 COLOR DATA INPUT ASSIGNMENT

The brightness of each primary color (red, green and blue) is based on the 8-bit gray scale data input for the color. The higher the binary input the brighter the color. The table below provides the assignment of color versus data input.

Color		Data Signal																							
		Red								Green								Blue							
		R7	R6	R5	R4	R3	R2	R1	R0	R7	R6	G5	G4	G3	G2	G1	G0	R7	R6	B5	B4	B3	B2	B1	B0
Basic Colors	Black	0	0	0	0	0	0	0	0	0	0	0	0	0	0	0	0	0	0	0	0	0	0	0	0
	Red	1	1	1	1	1	1	1	1	0	0	0	0	0	0	0	0	0	0	0	0	0	0	0	0
	Green	0	0	0	0	0	0	0	0	1	1	1	1	1	1	1	1	0	0	0	0	0	0	0	0
	Blue	0	0	0	0	0	0	0	0	0	0	0	0	0	0	0	0	1	1	1	1	1	1	1	1
	Cyan	0	0	0	0	0	0	0	0	1	1	1	1	1	1	1	1	1	1	1	1	1	1	1	1
	Magenta	1	1	1	1	1	1	1	1	0	0	0	0	0	0	0	0	1	1	1	1	1	1	1	1
	Yellow	1	1	1	1	1	1	1	1	1	1	1	1	1	1	1	1	0	0	0	0	0	0	0	0
	White	1	1	1	1	1	1	1	1	1	1	1	1	1	1	1	1	1	1	1	1	1	1	1	1
Gray Scale Of Red	Red(0) / Dark	0	0	0	0	0	0	0	0	0	0	0	0	0	0	0	0	0	0	0	0	0	0	0	0
	Red(1)	0	0	0	0	0	0	1	0	0	0	0	0	0	0	0	0	0	0	0	0	0	0	0	0
	Red(2)	0	0	0	0	0	1	0	0	0	0	0	0	0	0	0	0	0	0	0	0	0	0	0	0
	⋮	⋮	⋮	⋮	⋮	⋮	⋮	⋮	⋮	⋮	⋮	⋮	⋮	⋮	⋮	⋮	⋮	⋮	⋮	⋮	⋮	⋮	⋮	⋮	⋮
	⋮	⋮	⋮	⋮	⋮	⋮	⋮	⋮	⋮	⋮	⋮	⋮	⋮	⋮	⋮	⋮	⋮	⋮	⋮	⋮	⋮	⋮	⋮	⋮	⋮
	Red(252)	1	1	1	1	1	1	0	1	0	0	0	0	0	0	0	0	0	0	0	0	0	0	0	0
	Red(252)	1	1	1	1	1	1	1	0	0	0	0	0	0	0	0	0	0	0	0	0	0	0	0	0
	Red(252)	1	1	1	1	1	1	1	0	0	0	0	0	0	0	0	0	0	0	0	0	0	0	0	0
Gray Scale Of Green	Green(0)/Dark	0	0	0	0	0	0	0	0	0	0	0	0	0	0	0	0	0	0	0	0	0	0	0	0
	Green(1)	0	0	0	0	0	0	0	0	0	0	0	0	0	0	1	0	0	0	0	0	0	0	0	0
	Green(2)	0	0	0	0	0	0	0	0	0	0	0	0	0	1	0	0	0	0	0	0	0	0	0	0
	⋮	⋮	⋮	⋮	⋮	⋮	⋮	⋮	⋮	⋮	⋮	⋮	⋮	⋮	⋮	⋮	⋮	⋮	⋮	⋮	⋮	⋮	⋮	⋮	⋮
	⋮	⋮	⋮	⋮	⋮	⋮	⋮	⋮	⋮	⋮	⋮	⋮	⋮	⋮	⋮	⋮	⋮	⋮	⋮	⋮	⋮	⋮	⋮	⋮	⋮
	Green(252)	0	0	0	0	0	0	0	1	1	1	1	1	1	1	0	1	0	0	0	0	0	0	0	0
	Green(252)	0	0	0	0	0	0	0	1	1	1	1	1	1	1	1	0	0	0	0	0	0	0	0	0
	Green(252)	0	0	0	0	0	0	0	1	1	1	1	1	1	1	1	1	0	0	0	0	0	0	0	0
Gray Scale Of Blue	Blue(0) / Dark	0	0	0	0	0	0	0	0	0	0	0	0	0	0	0	0	0	0	0	0	0	0	0	0
	Blue(1)	0	0	0	0	0	0	0	0	0	0	0	0	0	0	0	0	0	0	0	0	0	0	0	1
	Blue(2)	0	0	0	0	0	0	0	0	0	0	0	0	0	0	0	0	0	0	0	0	0	0	1	0
	⋮	⋮	⋮	⋮	⋮	⋮	⋮	⋮	⋮	⋮	⋮	⋮	⋮	⋮	⋮	⋮	⋮	⋮	⋮	⋮	⋮	⋮	⋮	⋮	⋮
	⋮	⋮	⋮	⋮	⋮	⋮	⋮	⋮	⋮	⋮	⋮	⋮	⋮	⋮	⋮	⋮	⋮	⋮	⋮	⋮	⋮	⋮	⋮	⋮	⋮
	Blue(252)	0	0	0	0	0	0	0	0	0	0	0	0	0	0	0	1	1	1	1	1	1	1	0	1
	Blue(252)	0	0	0	0	0	0	0	0	0	0	0	0	0	0	0	1	1	1	1	1	1	1	1	0
	Blue(252)	0	0	0	0	0	0	0	0	0	0	0	0	0	0	0	1	1	1	1	1	1	1	1	1

Note (1) 0: Low Level Voltage, 1: High Level Voltage

## 6. INTERFACE TIMING

### 6.1 INPUT SIGNAL TIMING SPECIFICATIONS

The input signal timing specifications are shown as the following table and timing diagram.

Signal	Item	Symbol	Min.	Typ.	Max.	Unit	Note
DCLK	Pixel Clock	$1/T_C$	60.40	71.1	74.7	MHz	-
DE	Vertical Total Time	$T_V$	810	823	829	$T_H$	-
	Vertical Address Time	$T_{VD}$	800	800	800	$T_H$	-
	Horizontal Total Time	$T_H$	1362	1440	1480	$T_C$	-
	Horizontal Address Time	$T_{HD}$	1280	1280	1280	$T_C$	-

Note (1) Because this module is operated by DE only mode, Hsync and Vsync input signals should be set to low logic level or ground. Otherwise, this module would operate abnormally.

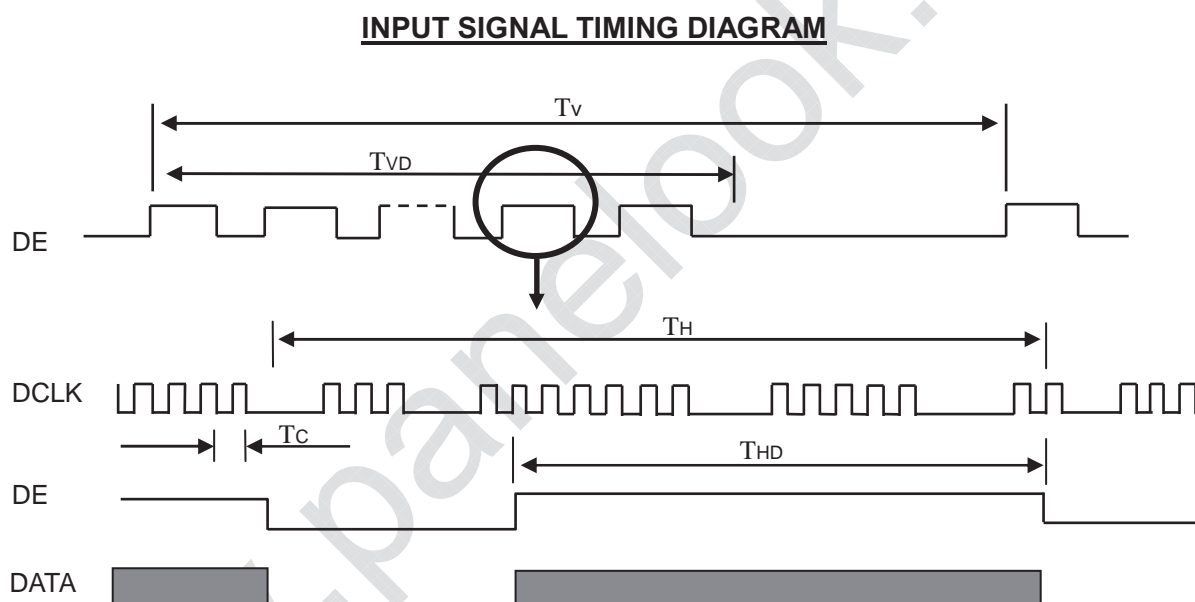

**TIMING DIAGRAM of LVDS**

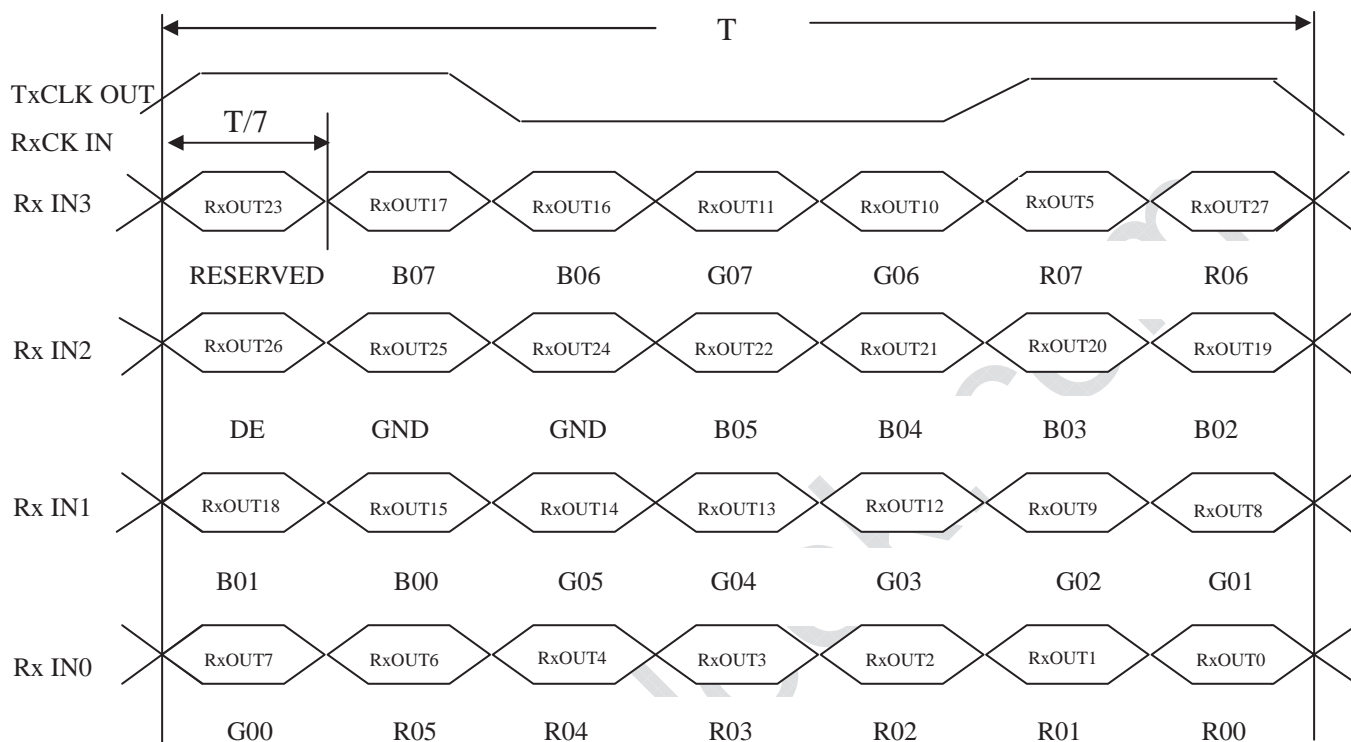

## 6.2 POWER ON/OFF SEQUENCE

To prevent a latch-up or DC operation of LCD assembly, the power on/off sequence should be as the diagram below.

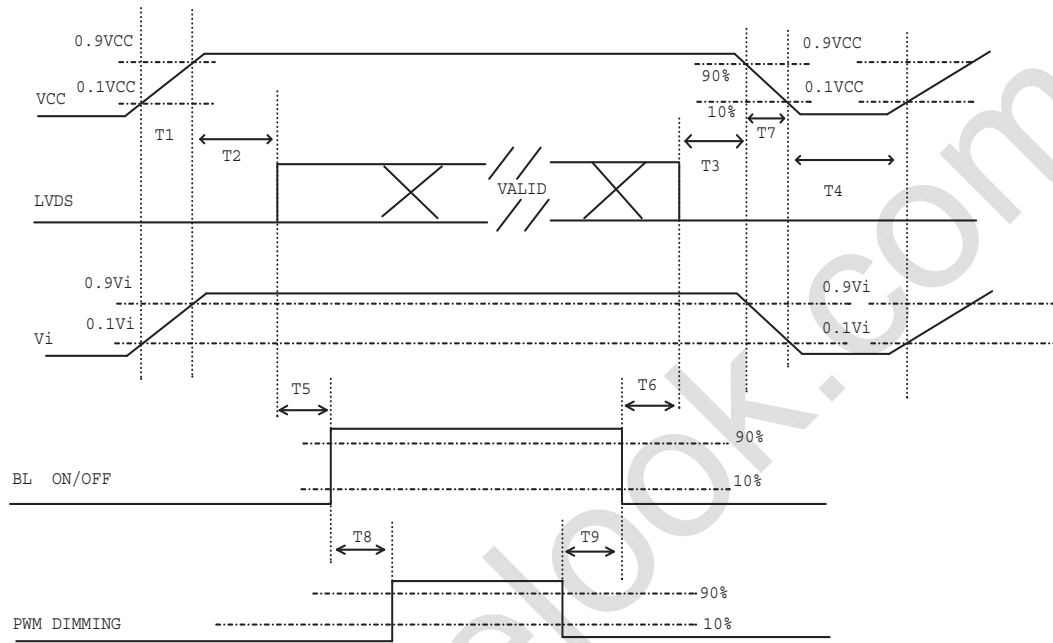

### Power ON/OFF sequence

Note (1) Please avoid floating state of interface signal at invalid period.

Note (2) When the interface signal is invalid, be sure to pull down the power supply of LCD VCC to 0 V.

Note (3) The Backlight converter power must be turned on after the power supply for the logic and the interface signal is valid. The Backlight converter power must be turned off before the power supply for the logic and the interface signal is invalid.

Parameter	Value			Units
	Min	Typ	Max	
T1	0.5	-	10	ms
T2	0	-	50	ms
T3	0	-	50	ms
T4	500	-	-	ms
T5	200	-	-	ms
T6	200	-	-	ms
T7	5	-	300	ms
T8	10	-	-	ms
T9	10	-	-	ms



## 7. OPTICAL CHARACTERISTICS

### 7.1 TEST CONDITIONS

Item	Symbol	Value	Unit
Ambient Temperature	Ta	25±2	°C
Ambient Humidity	Ha	50±10	%RH
Supply Voltage	V <sub>CC</sub>	3.3	V
Input Signal	According to typical value in "3. ELECTRICAL CHARACTERISTICS"		
Converter Voltage	V <sub>i</sub>	12	V
Converter Duty		100%	

### 7.2 OPTICAL SPECIFICATIONS

The relative measurement methods of optical characteristics are shown in 7.2. The following items should be measured under the test conditions described in 7.1 and stable environment shown in Note (5).

Item	Symbol	Condition	Min.	Typ.	Max.	Unit	Note	
Color Chromaticity	Red	$\theta_x=0^\circ, \theta_y=0^\circ$ CS-1000T	Typ - 0.05	0.592	Typ+ 0.05	-	(1), (5)	
				Ry				0.340
	Green			Gx				0.316
				Gy				0.591
	Blue			Bx				0.154
				By				0.123
	White			Wx				0.313
				Wy				0.329
Center Luminance of White	L <sub>C</sub>		900	1000		cd/m <sup>2</sup>	(4), (5)	
Contrast Ratio	CR		600	800		-	(2), (5)	
Response Time	T <sub>R</sub>	$\theta_x=0^\circ, \theta_y=0^\circ$	-	14	17	ms	(3)	
	T <sub>F</sub>			11	14			
White Variation	δW	$\theta_x=0^\circ, \theta_y=0^\circ$ USB2000	70	-	-	%	(5), (6)	
Viewing Angle	Horizontal	CR ≥ 10 USB2000	80	85	-	Deg.	(1), (5)	
				θ <sub>x-</sub>	85			-
	Vertical			θ <sub>y+</sub>	85			-
				θ <sub>y-</sub>	85			-

Note (1) Definition of Viewing Angle ( $\theta_x, \theta_y$ ):

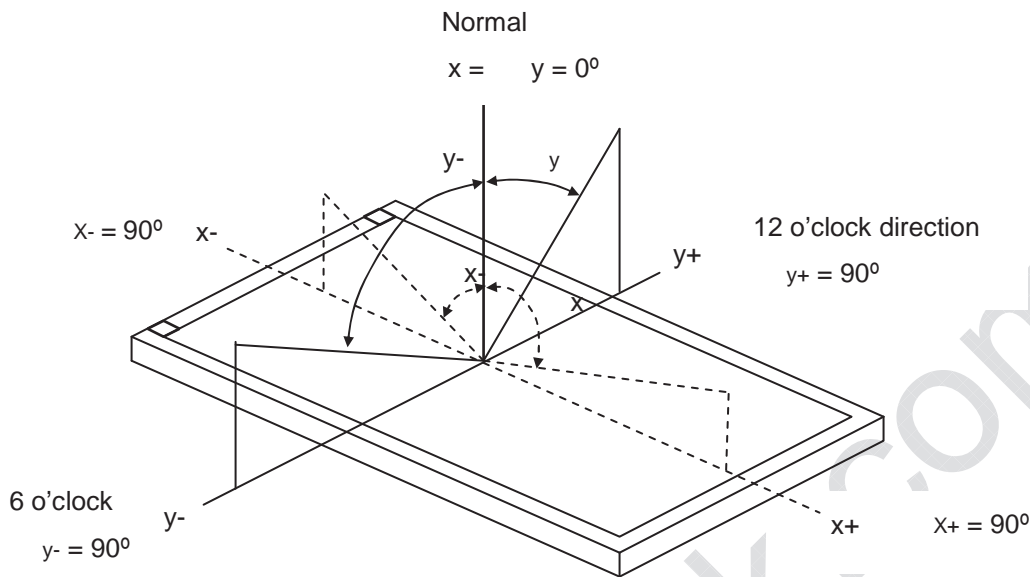

Note (2) Definition of Contrast Ratio (CR):

The contrast ratio can be calculated by the following expression.

$$\text{Contrast Ratio (CR)} = L_{252} / L_0$$

L252: Luminance of gray level 252

L0: Luminance of gray level 0

$$\text{CR} = \text{CR} (5)$$

CR (X) is corresponding to the Contrast Ratio of the point X at Figure in Note (6).

Note (3) Definition of Response Time ( $T_R, T_F$ ):

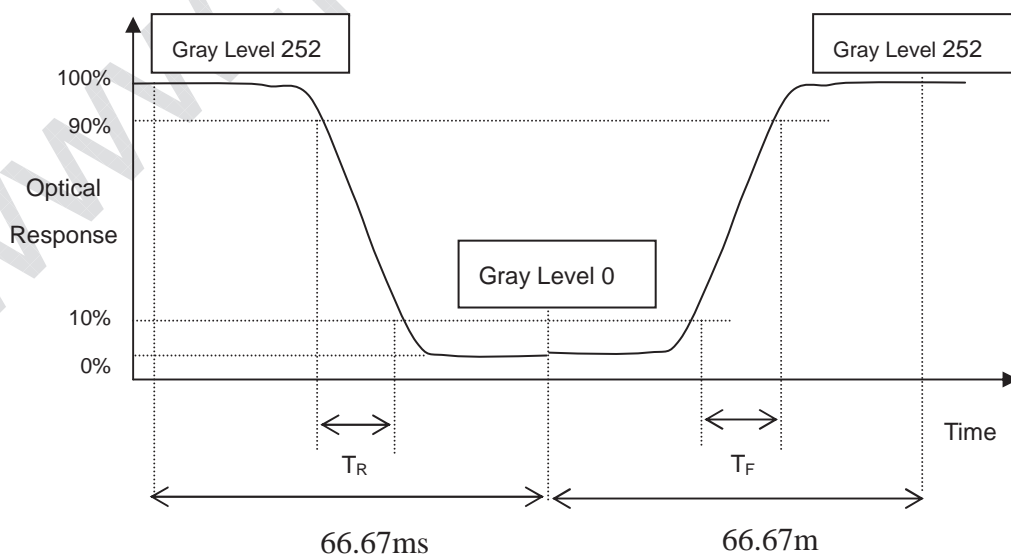

Note (4) Definition of Luminance of White ( $L_c$ ):

Measure the luminance of gray level 252 at center point

$$L_c = L(5)$$

$L(x)$  is corresponding to the luminance of the point X at Figure in Note (6).

Note (5) Measurement Setup:

The LCD module should be stabilized at given temperature for 20 minutes to avoid abrupt temperature change during measuring. In order to stabilize the luminance, the measurement should be executed after lighting Backlight for 20 minutes in a windless room.

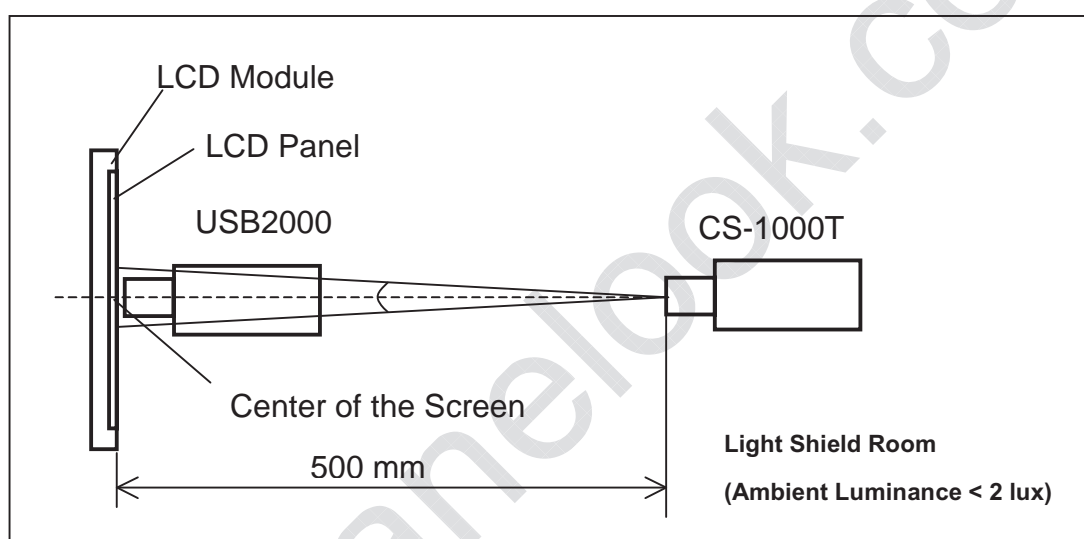

Note (6) Definition of White Variation ( $\delta W$ ):

Measure the luminance of gray level 252 at 5 points

$$W_{5p} = \{ \text{Minimum} [L(1) \sim L(5)] / \text{Maximum} [L(1) \sim L(5)] \} * 100\%$$

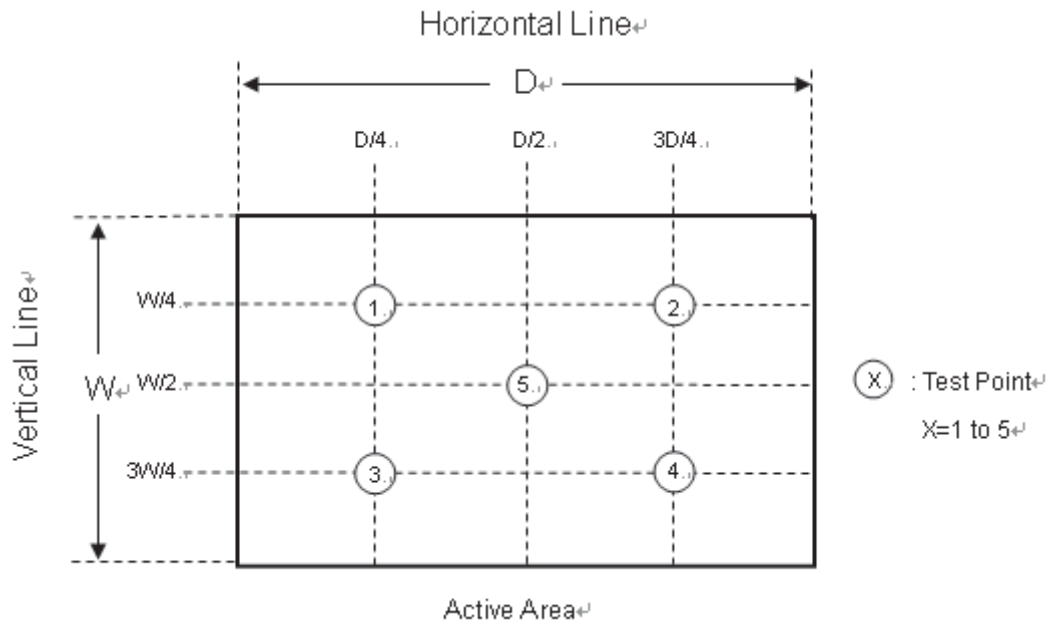

## 8. RELIABILITY TEST CRITERIA

Test Item	Test Condition	Note
High Temperature Storage Test	70°C, 240 hours	(1), (2) (4), (5)
Low Temperature Storage Test	-25°C, 240 hours	
Thermal Shock Storage Test	-25°C, 0.5 hour ↔ 70°C, 0.5 hour; 100cycles, 1 hour/cycle)	
High Temperature Operation Test	70°C, 240 hours	
Low Temperature Operation Test	-20°C, 240 hours	
High Temperature & High Humidity Operation Test	60°C, RH 90%, 240 hours	(1)
ESD Test (Operation)	150pF, 330Ω, 1 sec/cycle Condition 1 : panel contact, ±8 KV Condition 2 : panel non-contact ±15 KV	
Shock (Non-Operating)	50G, 11ms, half sine wave, 1 time for ± X, ± Y, ± Z direction	(1), (3)
Vibration (Non-Operating)	1.5G, 10 ~ 300 Hz sine wave, 10 min/cycle, 3 cycles each X, Y, Z direction	(1), (3)

Note (1) No display malfunction.

Note (2) Judgment should be tested after storage at room temperature for more than two hour. All the cosmetic specification is judged before reliability test.

Note (3) At testing Vibration and Shock, the fixture in holding the module has to be hard and rigid enough so that the module would not be twisted or bent by the fixture.

Note (4) Temperature of panel display surface area should be 75°C Max.

Note (5) Test condition for module only

## 9. PACKAGING

### 9.1 PACKING SPECIFICATIONS

- (1) 28pcs LCD modules / 1 Box
- (2) Box dimensions: 435(L) X 350 (W) X 275 (H) mm
- (3) Weight: approximately 12.02Kg (28 modules per box)

### 9.2 PACKING METHOD

- (1) Box Dimensions : 435(L)\*350(W)\*275(H)
- (2) 28 Modules/Carton

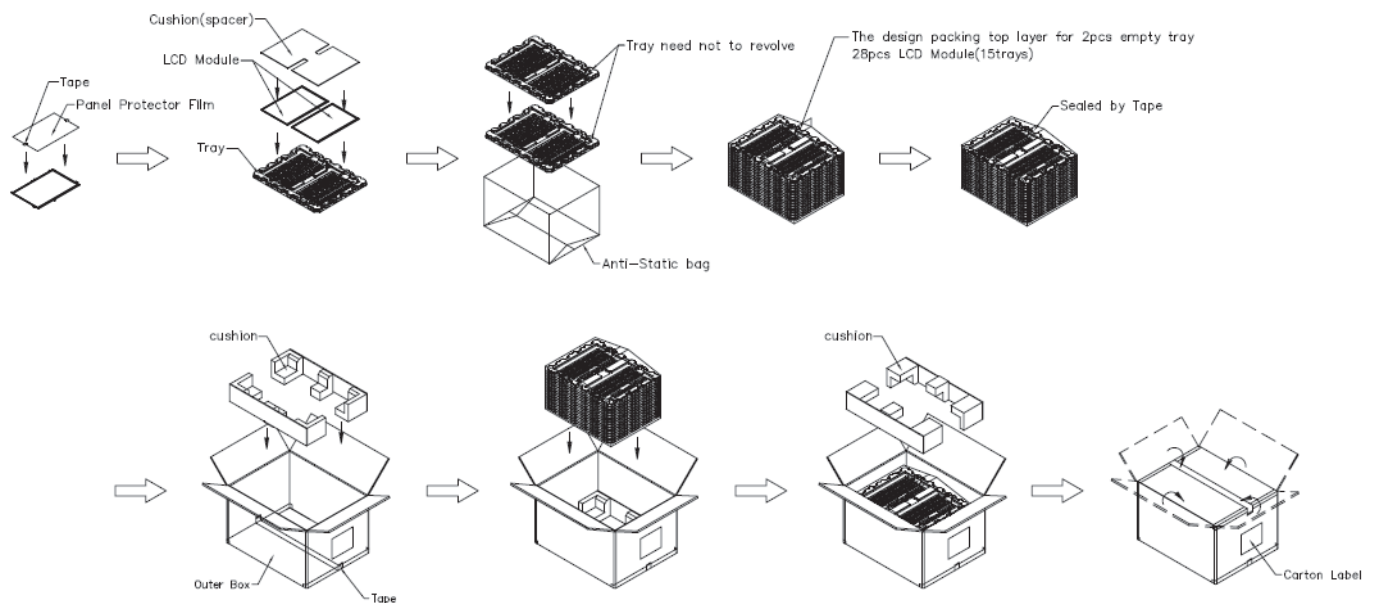

Figure. 9-1 Packing method

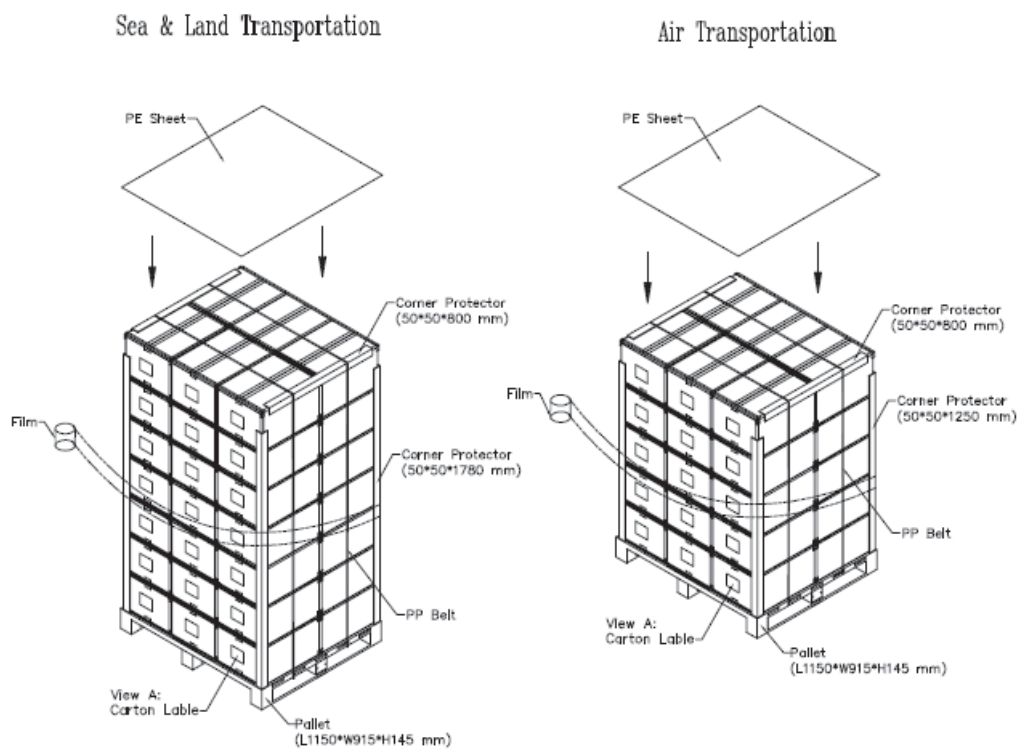

Figure. 9-2 Packing method

9.3 UN-PACKING METHOD

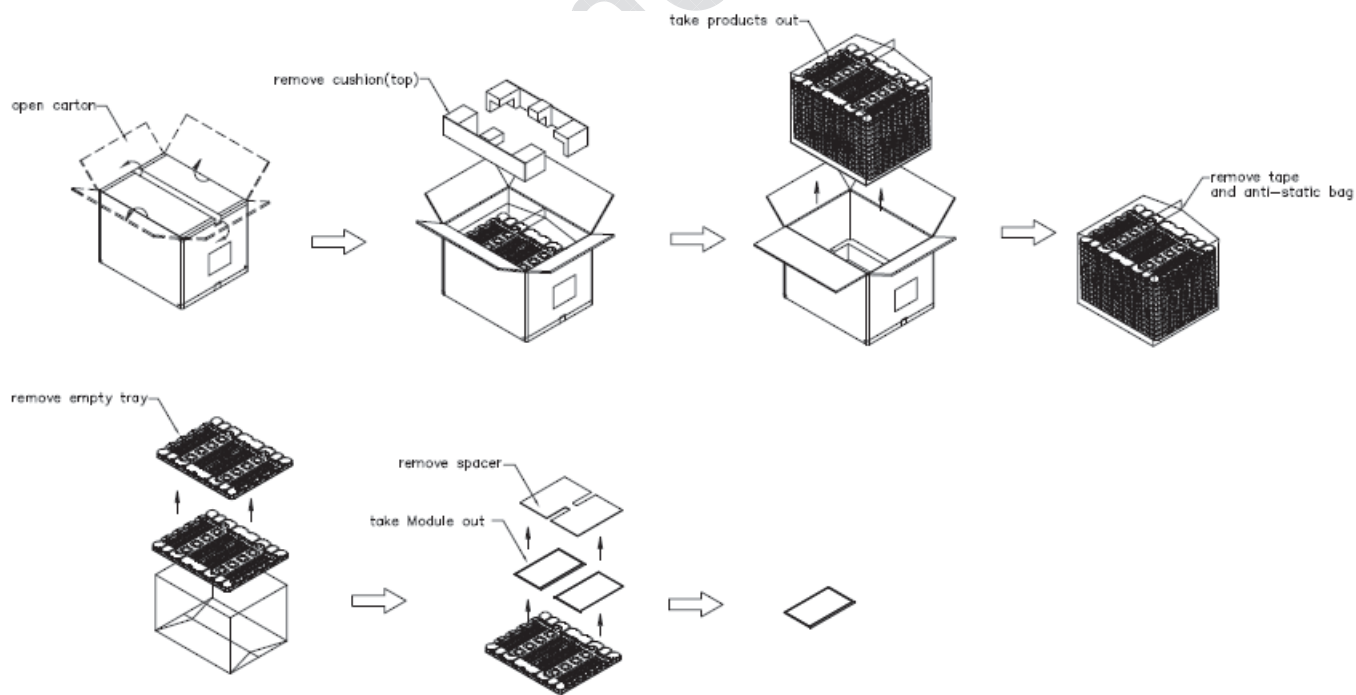
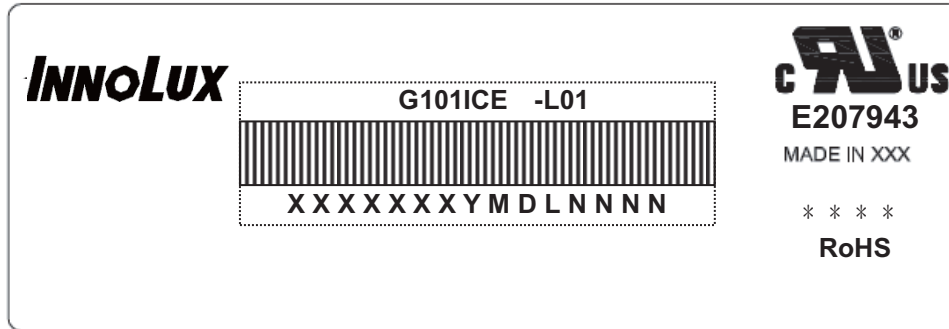

Figure. 9-3 UN-Packing method

## 10. DEFINITION OF LABELS

### 10.1 INX MODULE LABEL

The barcode nameplate is pasted on each module as illustration, and its definitions are as following explanation.



- (a) Model Name: G101ICE -L01
- (b) Revision: Rev. XX, for example: A1, B1, C1, C2 ...etc.
- (c) \* \* \* \* : Factory ID
- (d) Serial ID: X X X X X X X Y M D X N N N N

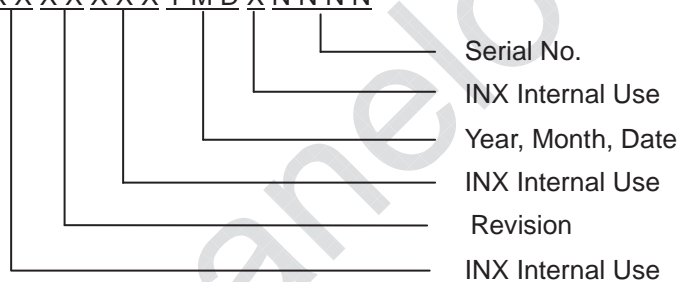

Serial ID includes the information as below:

- (a) Manufactured Date: Year: 1~9, for 2011~2019  
 Month: 1~9, A~C, for Jan. ~ Dec.  
 Day: 1~9, A~Y, for 1<sup>st</sup> to 31<sup>st</sup>, exclude I, O and U
- (b) Revision Code: cover all the change
- (c) Serial No.: Manufacturing sequence of product



## 11. PRECAUTIONS

### 11.1 ASSEMBLY AND HANDLING PRECAUTIONS

- (1) Do not apply rough force such as bending or twisting to the module during assembly.
- (2) To assemble or install module into user's system can be only in clean working areas. The dust and oil may cause electrical short or worsen the polarizer.
- (3) It's not permitted to have pressure or impulse on the module because the LCD panel and Backlight will be damaged.
- (4) Always follow the correct power sequence when LCD module is connecting and operating. This can prevent damage to the CMOS LSI chips during latch-up.
- (5) Do not pull the I/F connector in or out while the module is operating.
- (6) Do not disassemble the module.
- (7) Use a soft dry cloth without chemicals for cleaning, because the surface of polarizer is very soft and easily scratched.
- (8) It is dangerous that moisture come into or contacted the LCD module, because moisture may damage LCD module when it is operating.
- (9) High temperature or humidity may reduce the performance of module. Please store LCD module within the specified storage conditions.
- (10) When ambient temperature is lower than 10°C may reduce the display quality. For example, the response time will become slowly.
- (11) Do not keep same pattern in a long period of time. It may cause image sticking on LCD.

### 11.2 SAFETY PRECAUTIONS

- (1) Do not disassemble the module or insert anything into the Backlight unit.
- (2) If the liquid crystal material leaks from the panel, it should be kept away from the eyes or mouth. In case of contact with hands, skin or clothes, it has to be washed away thoroughly with soap.
- (3) After the module's end of life, it is not harmful in case of normal operation and storage.

12. MECHANICAL CHARACTERISTICS

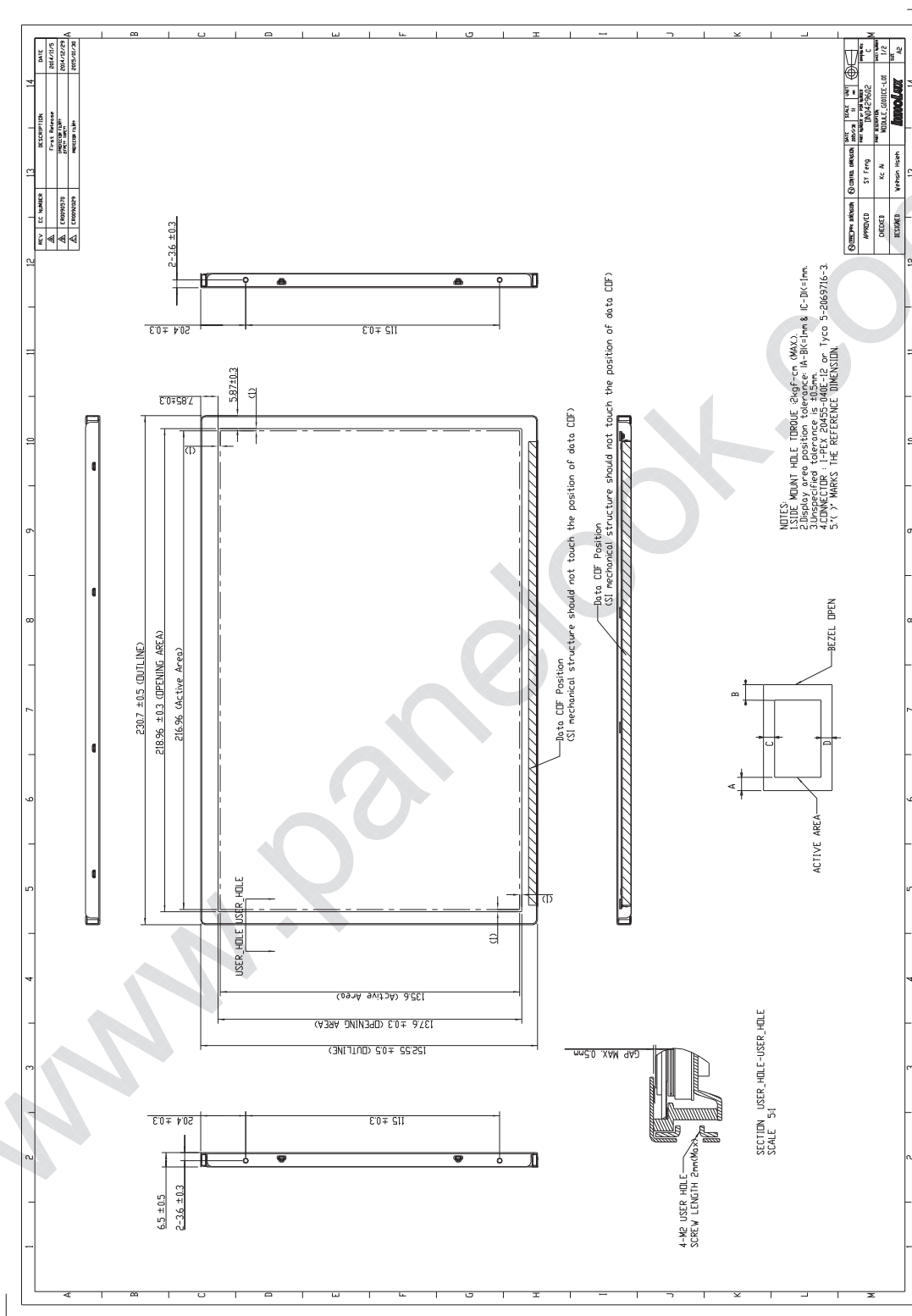

# PRODUCT SPECIFICATION

